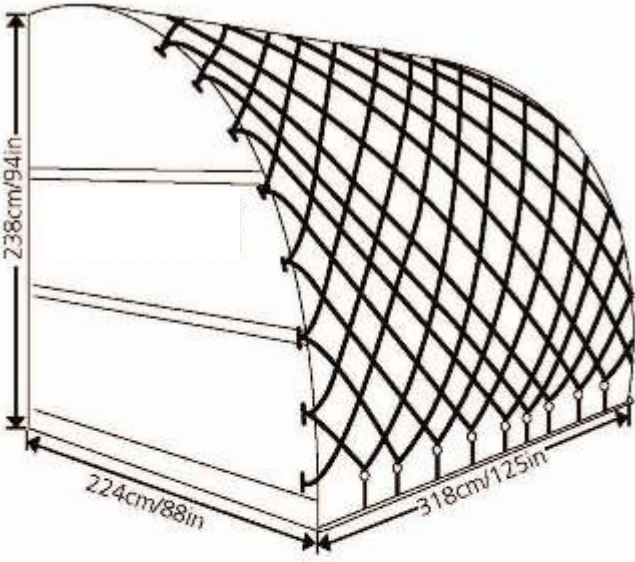
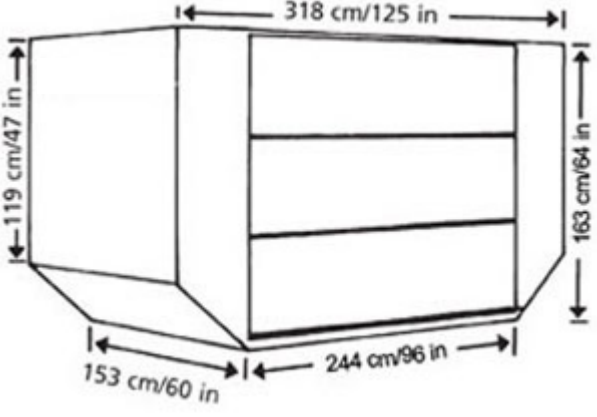

## Air Freight Unit Load Devices

Large aircraft such as the Boeing 747 employ quick-loading containers known as Unit Load Devices (ULDs), much like containerized cargo ships. The ULDs are located in front section of the aircraft.

A unit load device, or ULD, is a pallet or container used to load luggage, freight, and mail on wide-body aircraft and specific narrow-body aircraft. It allows a large quantity of cargo to be bundled into a single unit. Since this leads to fewer units to load, it saves ground crews time and effort and helps prevent delayed flights. Each ULD has its own packing list (or manifest) so that its contents can be tracked.

ULDs come in two forms: pallets and containers. ULD pallets are rugged sheets of aluminum with rims designed to lock onto cargo net lugs. ULD containers, also known as cans and pods, are closed containers made of aluminum or combination of aluminum (frame) and Lexan (walls), which, depending on the nature of the goods to be transported, may have built-in refrigeration units. Examples of common ULDs and their specifics are listed below.

	<p>ID Code</p> <p>Aircraft Types</p> <p>Main or Lower Deck</p> <p>Rate Class</p> <p>Internal Volume</p> <p>Limiting</p> <p>Internal Dimensions</p> <p>Maximum Gross Weight</p> <p>Tare Weight (incl. Net)</p> <p>IATA Contour Code</p>	<p>AAX</p> <p>767 Freighter</p> <p>Main Deck</p> <p>--</p> <p>13.6m<sup>3</sup> (480 cu ft)</p> <p>208 x 302 x 238 cm (82 x 119 x 94in)</p> <p>6,033kg (13,000lb)</p> <p>225kgs</p>
	<p>ID Code</p> <p>Aircraft Types</p> <p>Main or Lower Deck</p> <p>Rate Class</p> <p>Internal Volume</p> <p>Internal Dimensions</p> <p>At Base</p> <p>Maximum Gross Weight</p> <p>Tare Weight (incl. Net)</p> <p>IATA Contour Code</p>	<p>DLF, DQF</p> <p>767</p> <p>Lower Deck</p> <p>6A</p> <p>7.2 m<sup>3</sup> (253 cu ft)</p> <p>140 x 233 x 152 cm (55 x 92 x 60 in)</p> <p>2449 kg (5400 lb)</p> <p>F</p>

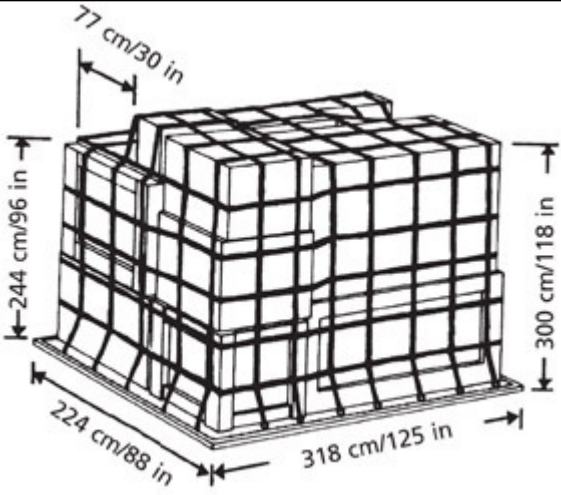
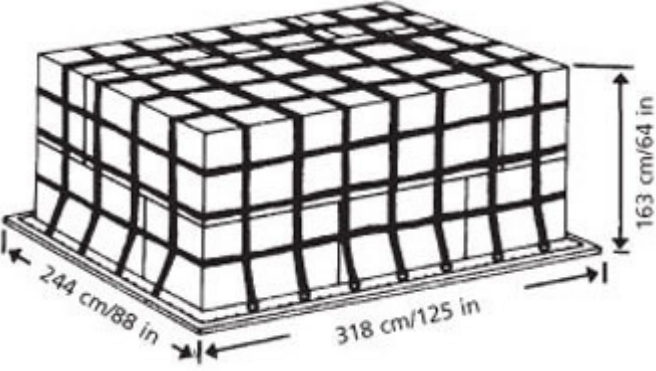
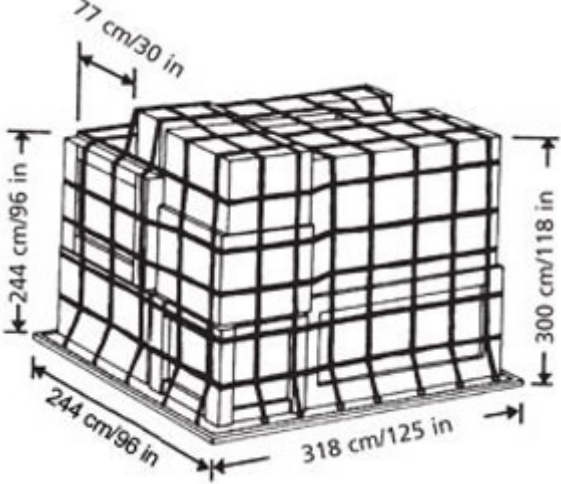
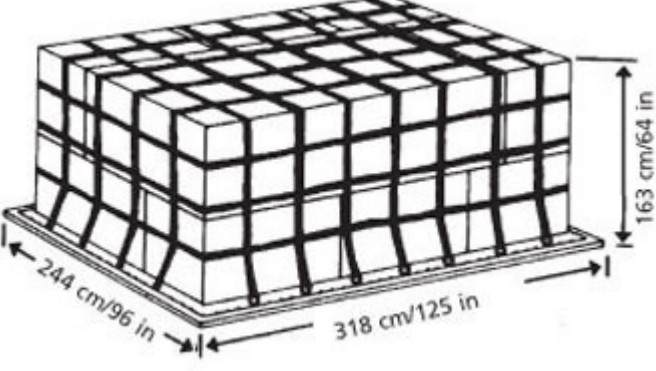
	<p>ID Code</p> <p>Aircraft Types</p> <p>Main or Lower Deck</p> <p>Rate Class</p> <p>Internal Volume</p> <p>Limiting</p> <p>Internal Dimensions</p> <p>Maximum Gross Weight</p> <p>Tare Weight (incl. Net)</p> <p>IATA Contour Code</p>	<p>P1P, PAG, PAP, PAJ, P1G</p> <p>747 Freighter</p> <p>Main Deck</p> <p>2C</p> <p>--</p> <p>--</p> <p>6800 kg (15000 lb)</p> <p>110 kg (242 lb)</p> <p>D or M</p>
	<p>ID Code</p> <p>Aircraft Types</p> <p>Main or Lower Deck</p> <p>Rate Class</p> <p>Internal Volume</p> <p>Limiting</p> <p>Internal Dimensions</p> <p>Maximum Gross Weight</p> <p>Tare Weight (incl. Net)</p> <p>IATA Contour Code</p>	<p>P1P, PAG, PAP, PAJ, P1G</p> <p>All 747, 767 &amp; A330</p> <p>Lower Deck</p> <p>5</p> <p>--</p> <p>--</p> <p>4626 kg (10200 lb)</p> <p>110 kg (242 lb)</p> <p>P</p>
	<p>ID Code</p> <p>Aircraft Types</p> <p>Main or Lower Deck</p> <p>Rate Class</p> <p>Internal Volume</p> <p>Limiting</p> <p>Internal Dimensions</p> <p>Maximum Gross Weight</p> <p>Tare Weight (incl. Net)</p> <p>IATA Contour Code</p>	<p>P1P, PAG, PAP, PAJ, P1G</p> <p>747 Freighter</p> <p>Main Deck</p> <p>2H</p> <p>--</p> <p>--</p> <p>6800 kg (15000 lb)</p> <p>110 kg (242 lb)</p> <p>A or D</p>
	<p>ID Code</p> <p>Aircraft Types</p> <p>Main or Lower Deck</p> <p>Rate Class</p> <p>Internal Volume</p> <p>Limiting</p> <p>Internal Dimensions</p> <p>Maximum Gross Weight</p> <p>Tare Weight (incl. Net)</p> <p>IATA Contour Code</p>	<p>P6P, PMC</p> <p>All 747, 767 &amp; A330</p> <p>Lower Deck</p> <p>2BG</p> <p>--</p> <p>--</p> <p>5100 kg (11243 lb)</p> <p>110 kg (242 lb)</p> <p>P</p>

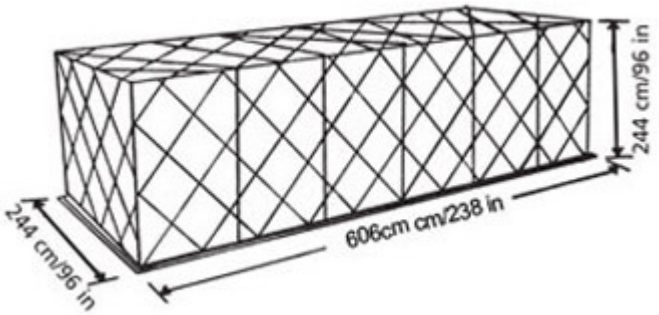
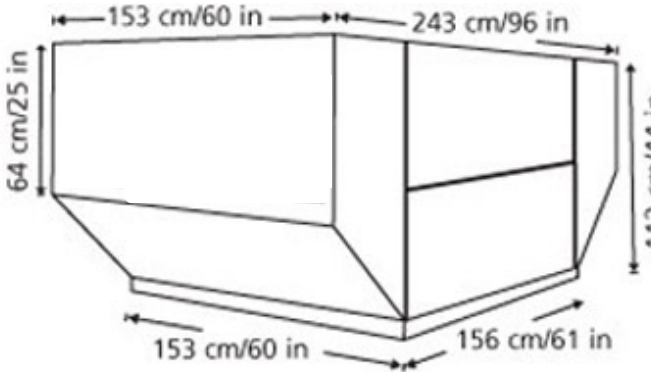
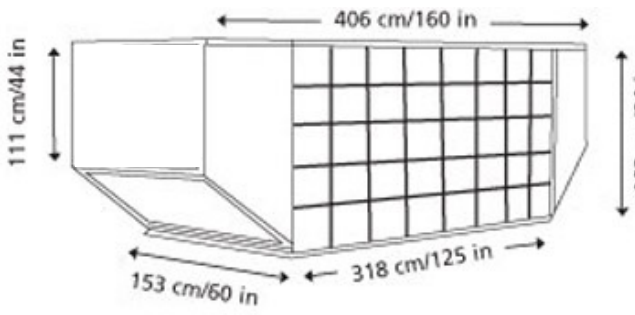
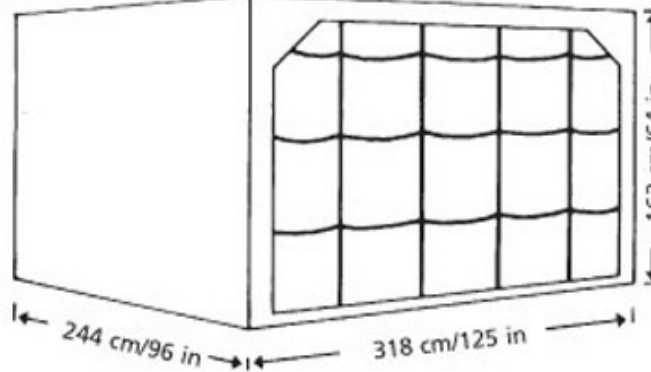
	<p>ID Code</p> <p>Aircraft Types</p> <p>Main or Lower Deck</p> <p>Rate Class</p> <p>Internal Volume</p> <p>Limiting</p> <p>Internal Dimensions</p> <p>Maximum Gross Weight</p> <p>Tare Weight (incl. Net)</p> <p>IATA Contour Code</p>	<p>PGA</p> <p>B747 Freighter</p> <p>Main Deck</p> <p>1</p> <p>--</p> <p>--</p> <p>Varies according to aircraft loading position</p> <p>578 kg (1274 lb)</p> <p>A</p>
	<p>ID Code</p> <p>Aircraft Types</p> <p>Main or Lower Deck</p> <p>Rate Class</p> <p>Internal Volume</p> <p>Limiting</p> <p>Internal Dimensions</p> <p>At Base</p> <p>Maximum Gross Weight</p> <p>Tare Weight</p> <p>IATA Contour Code</p>	<p>AKH</p> <p>A320</p> <p>Main Deck</p> <p>8A</p> <p>3.6 m<sup>3</sup> (127 cu ft)</p> <p>146 x 149 x 113 cm</p> <p>1000 kg (2204.6 lb)</p> <p>80 kg (176 lb)</p> <p>H</p>
	<p>ID Code</p> <p>Aircraft Types</p> <p>Main or Lower Deck</p> <p>Rate Class</p> <p>Internal Volume</p> <p>Limiting</p> <p>Internal Dimensions</p> <p>At Base</p> <p>Maximum Gross Weight</p> <p>Tare Weight</p> <p>IATA Contour Code</p>	<p>ALF</p> <p>All B747 + A330</p> <p>Lower Deck</p> <p>6W</p> <p>8.9 m<sup>3</sup> (314 cu ft)</p> <p>295 x 149 x 152 cm (116 x 59 x 60 in)</p> <p>3175 kg (7000 lb)</p> <p>160 kg</p> <p>F</p>
	<p>ID Code</p> <p>Aircraft Types</p> <p>Main or Lower Deck</p> <p>Rate Class</p> <p>Internal Volume</p> <p>Limiting</p> <p>Internal Dimensions</p> <p>Maximum Gross Weight</p> <p>Tare Weight</p> <p>IATA Contour Code</p>	<p>AMP</p> <p>All 747, 767 &amp; A330</p> <p>Lower Deck</p> <p>2BG</p> <p>11.4 m<sup>3</sup> (403 cu ft)</p> <p>229 X 302 X 152 cm (90 x 119 x 60 in)</p> <p>5100 kg (11243 lb)</p> <p>266 kg (587 lb)</p> <p>P</p>

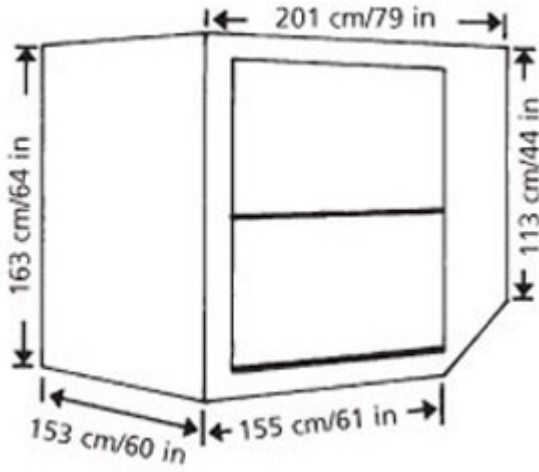
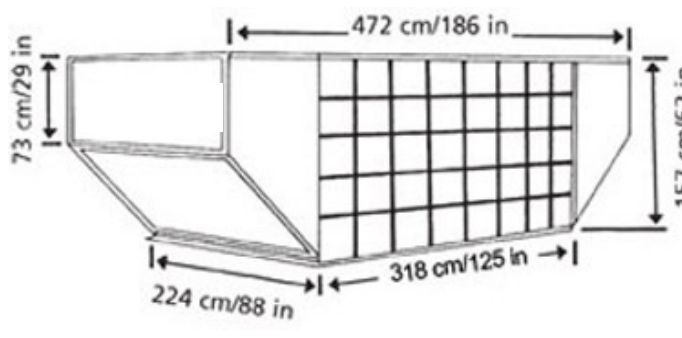
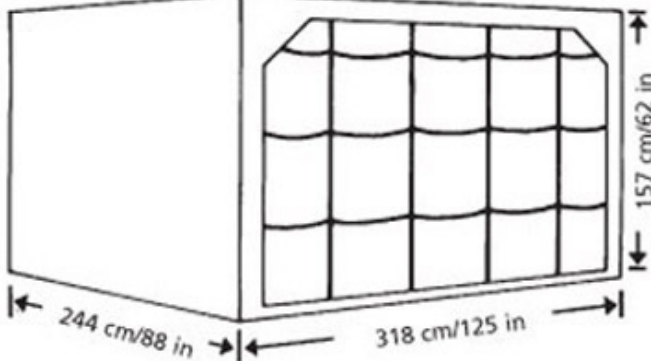
	<p>ID Code</p> <p>Aircraft Types</p> <p>Main or Lower Deck</p> <p>Rate Class</p> <p>Internal Volume</p> <p>Limiting</p> <p>Internal Dimensions</p> <p>At Base</p> <p>Maximum Gross Weight</p> <p>Tare Weight</p> <p>IATA Contour Code</p>	<p>AMP</p> <p>All 747, 767 &amp; A330</p> <p>Lower Deck</p> <p>8</p> <p>4.3 m<sup>3</sup> (153 cu ft)</p> <p>140 x 147 x 152 cm (55 x 58 x 60 in)</p> <p>1587 kg (3500 lb)</p> <p>E</p>
	<p>ID Code</p> <p>Aircraft Types</p> <p>Main or Lower Deck</p> <p>Rate Class</p> <p>Internal Volume</p> <p>Limiting</p> <p>Internal Dimensions</p> <p>At Base</p> <p>Maximum Gross Weight</p> <p>Tare Weight</p> <p>IATA Contour Code</p>	<p>AMP</p> <p>All 747 &amp; A330</p> <p>Lower Deck</p> <p>5WA</p> <p>13.0 m<sup>3</sup> (459 cu ft)</p> <p>208 X 302 X 152 cm (82 X 119 X 60 in)</p> <p>4626 kg (10200 lb)</p> <p>268 kg (590 lb)</p> <p>F</p>
	<p>ID Code</p> <p>Aircraft Types</p> <p>Main or Lower Deck</p> <p>Rate Class</p> <p>Internal Volume</p> <p>Limiting</p> <p>Internal Dimensions</p> <p>Maximum Gross Weight</p> <p>Tare Weight</p> <p>IATA Contour Code</p>	<p>AA2, AAP</p> <p>All 747, 767 &amp; A330</p> <p>Lower Deck</p> <p>5</p> <p>10.6 m<sup>3</sup> (374 cu ft)</p> <p>208 X 302 X 152 cm (82 X 119 X 60 in)</p> <p>4626 kg (10200 lb)</p> <p>P</p>